

## Product Specification

For the

## TK419 Tracking Device

By

## EELink Communication Technology Co. Ltd

May 24, 2019

The information presented in this document is strictly confidential and contains trade secrets and other confidential information that are the exclusive property of Shenzhen EELink Communication Technology Co. Ltd, its parent, subsidiaries or agents.

### Document reference

Revision: V1.00 Draft

Author: Mr. Cheng

Release date: Date first printed above

File name: TK419\_Overview\_190524.docx

### Authorized Recipients

Executive management as provided to and are bound by a Non-Disclosure Agreement (NDA) in favor of EELink, its parent or its agent and preventing disclosure or misuse of the confidential information herein.

### Revision History

Revision	Date	Description
V1.00	2019/05/24	First draft release



## Scope

This document sets forth the basic technical requirements and feature set for the TK419 tracking device.

## Description

The TK419 Tracker is a self-contained, integrated commercial grade vehicle tracking device that uses GPS (Qualcomm solution: Gen8C Lite) satellite location in combination with a LTE category 1 module optimized specially for M2M and IOT applications to report that location. LTE module features cost-effective, low power LTE connectivity, and delivers M2M-optimized speeds of 10Mbps downlink and 5Mbps uplink. The TK419 is optimized for reliability, low data flows and size. The TK419 is an optimized version of EELink standard tracker that is targeted at expandable and truck, cargo or electric motor oriented IOT applications etc. The TK419 is also targeted at the property tracking market.

All antennas including the GPS patch and LTE antenna are internal to the device. Data reporting can be initiated by a server or by the tracker itself via LTE's SMS, TCP/IP or UDP pathways or over a physical USB connection.

The TK419 is comprised of a simple two piece of plastic enclosure which is waterproof IP65 for reliability, durability and low cost assembly.

The TK419 can be provisioned for TCP/IP, UDP and SMS data services for application command and/or data transactions within B2/B3/B5/B8 GSM bands; B1/B2/B5/B8 WCDMA bands; B1/B2/B3/B4/B5/B7/B8/B28 LTE FDD bands and B40 LTE TDD band.

Over The Air (OTA) application firmware updates are supported through at TFTP connection to a server. The high level application image can be updated by using one specialized SMS or UART command.

The TK419 is physically disguised to appear to be a nondescript part of the cabling system. It is a small black box with unremarkable features. Two LED status indicators are provided to verify correct installation and initial operation. A unique power management feature allows these LEDs to be extinguished once installation is verified to be correct. This feature reduces power and further conceals the TK419 Tracker from untrained parties wishing to defeat its operation.

As with all GPS location devices, the TK419 should be installed in a vehicle/battery pack such that it has an unobstructed view of the sky during normal operation. Double sided foam tape can be used to secure the surface not facing the sky if needed.

A factory populate option is provided to add a motion detector to the main board. Under software control, this motion detector can be used to wake up the TK419 from a very low power state.

## Bullet Specifications

---

### Features

#### LTE:

FDD	B1/B2/B3/B4/B5/B7/B8/B28 Max 10Mbps (DL)/Max 5Mbps (UL)
TDD	B40 Max 8.96Mbps (DL)/Max 3.1Mbps (UL)

#### UMTS:

	B1/B2/B5/B8
WCDMA	Max 384Kbps (DL)/Max 384Kbps (UL)
DC-HSDPA	Max 42Mbps (DL)
HSUPA	Max 5.76Mbps (UL)

#### GSM:

	B2/B3/B5/B8
EDGE	Max 296Kbps (DL)/Max 236.8Kbps (UL)
GPRS	Max 107Kbps (DL)/Max 85.6Kbps (UL)

SMS                      Text and PDU mode  
                              Point to Point MO and MT  
                              SMS cell broadcast

### Protocols:

Embedded TCP/IP, UDP/IP, PPP, HTTP/NTP/QMI etc.

---

### Power consumption

Power off	20uA
Sleep, Type	3mA
Idle	22mA
GPRS data transfer	about 500mA
WCDMA data transfer	about 700mA
LTE data transfer	about 800mA

---

### Certifications and approvals (only for module)

GCF (Global), CE, PTCRB, RCM, FCC, IC, JATE, Anatel, FAC, CCC etc.

---

### Other features

- Cell Locate
- Firmware upgrade via USB
- Firmware upgrade by means of the FOAT feature
- Designed for worldwide operation

---

**Supply Power:**              Vin: 9.0 – 72.0V DC

---

### Cellular output power

- Class 3 (23 +/-2dBm) @ LTE FDD Bands
- Class 3 (23 +/-2dBm) @ LTE TDD Bands
- Class 3 (24 +1/-3dBm) @ WCDMA Bands
- Class E2 (27 +/-3dBm) @ GSM850 8-PSK

---

Class E2 (27 +/-3dBm) @ GSM900 8-PSK  
Class E2 (26 +/-3dBm) @ GSM1800 8-PSK  
Class E2 (26 +/-3dBm) @ GSM1900 8-PSK  
Class 4 (33 +/-2dBm) @ GSM850 Bands  
Class 4 (33 +/-2dBm) @ GSM900 Bands  
Class 1 (30 +/-2dBm) @ DCS1800 Bands  
Class 1 (30 +/-2dBm) @ PCS1900 Bands

**Cellular Sensitivity:**

LTE B1: -101dBm  
LTE B2: -101dBm  
LTE B3: -101dBm  
LTE B4: -101dBm  
LTE B5: -101dBm  
LTE B7: -99.5dBm  
LTE B8: -101dBm  
LTE B28: -102dBm  
WCDMA B1: -110dBm  
WCDMA B2: -110dBm  
WCDMA B5: -110dBm  
WCDMA B8: -110dBm  
GSM850: -109dBm  
EGSM900: -109dBm  
DSC1800: -109dBm  
PCS1900: -109dBm

---

**Backup Battery:**

Embedded 140mAh battery for emergency alarm when removing main power.

---

**Software:**

Native ARM processor execution  
Proprietary application  
    Extended AT command interface  
    Easily configured reports to minimize data transport costs  
    Based on proven GPRS/UMTS/HSPA/LTE modem stack  
Lockup protection:  
    Independent watchdog with power cycle reset and reboot

---

Flash memory:

4MB for application and data storage

Report buffer

USB port update for application level software

Over the air update for application level software

Development:

Complete C language tool chain

---

### **Motion sensor:**

Embedded 3D motion sensor

Detecting moving status for saving consumption.

---

### **Physical:**

Design: Nondescript design

Color: Black

Texture: Light

Material: UL Lanxess PA6 Durethan BKV15+

Size: 89mm x 37mm x 12mm

Weight: **TBDg**

Label: LED ported, and laser printable

SIM: Keyed retainer socket

---

### **Environment:**

Temperature:

-20 to 75° C Operation

-50 to +100° C Storage

Humidity:

20% to 90% Operation

10% to 95% Storage

ESD: 15KV immune on all user accessible surfaces and ports

Altitude: -500 to +18,000m

Shock: 25G

---

### **GNSS Receiver:**

Supports Gen8C-Lite of Qualcomm: GPS, GLONASS, BeiDou, Galileo and QZSS

Sensitivity:

---

Cold start: -146dBm  
Reacquisition: -157dBm  
Tracking: -157dBm

TTF:

Cold start: 35s @ open sky  
Warm start: 26s @ open sky  
Hot start: 3s @ open sky

Accuracy CEP-50: < 2 m

Embedded 25x25x4mm patch antenna

---

## Hardware Architecture

Figure 1 shows a high level block diagram of the TK419 system hardware. The core architecture is defined a highly integrated Qualcomm chipset module embedded GNSS receiver. The motion detector is optionally populated at assembly time.

**Figure 1**  
**TK419 Hardware Architecture Block Diagram**

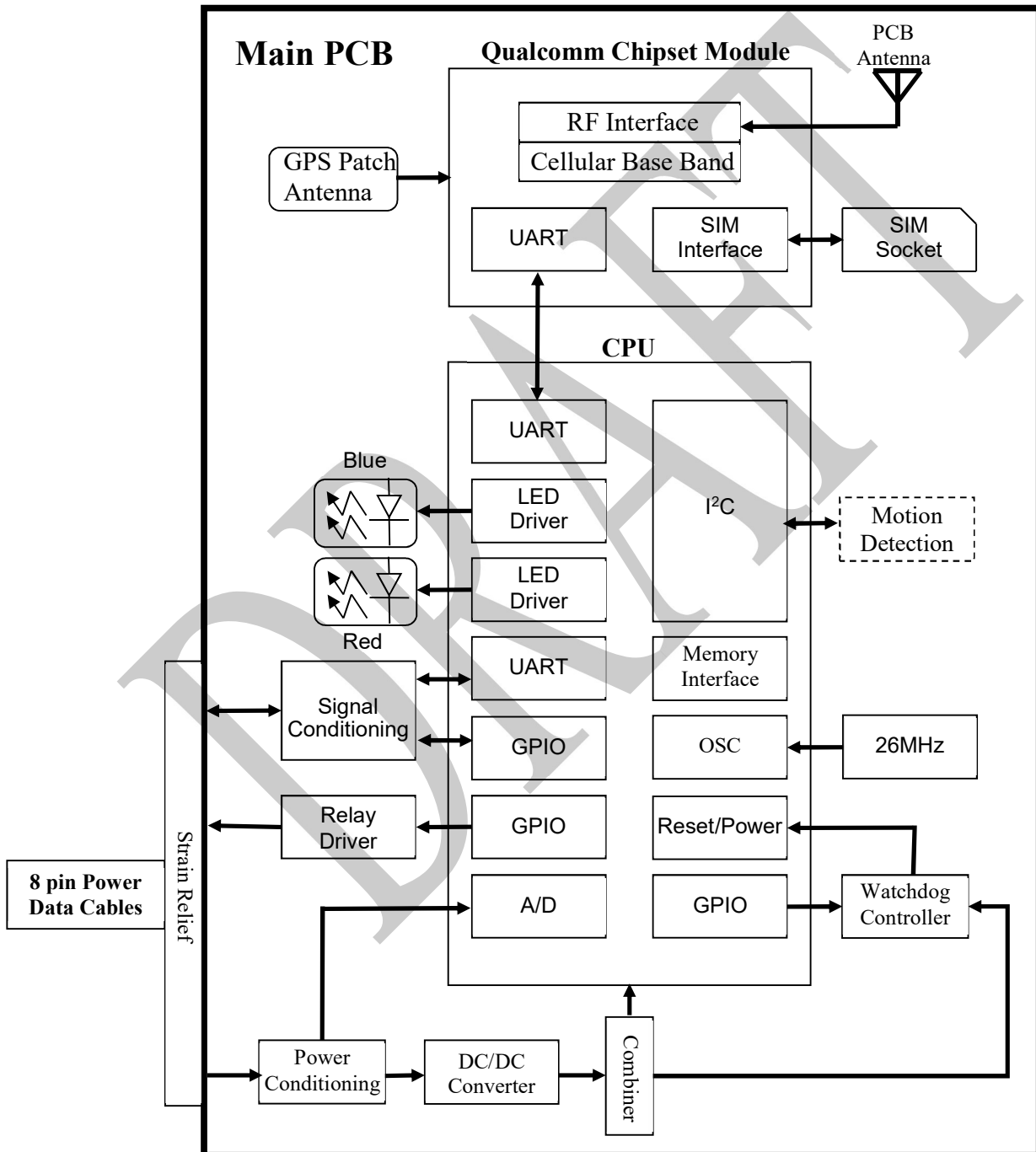



## Software Architecture

The application software resides in module system flash memory and operates directly under control of the native OS. The TK419 does use an external applications processor to communicate with Qualcomm chipset module by UART.

### Structure

Figure 2 shows a high level application software block diagram of the basic architecture. The OS is closely knit with a debugger allowing for code development, maintenance and updates over the UART or USB. The boot loader provides control over all code and configuration memory. The watchdog is a dedicated hardware device that will issue a hardware reset to the unit in conjunction with a power cycle operation if it is not maintained by a periodic ping from the application program.

**Figure 2**  
**TK419 Application level Software Architecture**

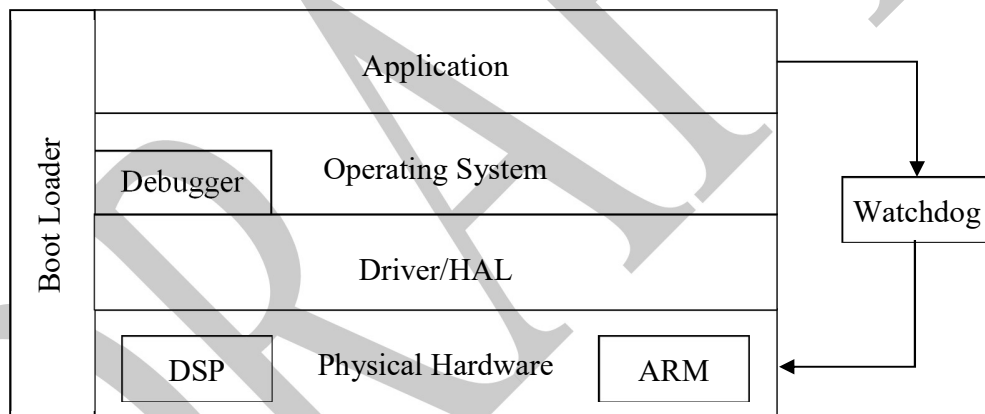

### Features

TK419 acts like a LTE modem and responds to AT commands issued to it from either a physical UART port connection or to AT commands issued to it through an SMS, TCP/IP or UDP/IP connection. With regard to text messages, TK419 “reads” all of its own text messages and tries to interpret each message as an AT command. SMS text may be sent to a TK419 through any CSD SMS connection.

Key superset functions outside that of typical LTE modems support intrinsic TK419 Features. These functions include:

- Automatic field lockup recovery
  - Hardware watchdog with power and reset cycle
  - Circuit Switched Data (SMS) code maintenance

- Hard reset
- Restore factory defaults
- Application level software download using OTA
- Specialized GPS functions including
  - GPS data reporting
  - GPS status reporting
  - GPS power control
  - Setup and monitor geographic fences
- Device initiated TCP/IP or UDP reporting
  - Recurring schedule event
  - Low battery condition
  - Report record queue
  - User defined IP addresses
  - Geographic fence violation
- Virtual AT command processor over SMS or TCP/IP or UDP/IP connection
- OTA code update using TFTP
  - 100% buffered
  - Established standard protocol
- APN support with optional credential verification

### Physical Attributes

Figures 3A and 3B show various exterior views and dimensions of the TK419 Tracker and some critical physical features.

**Figure 3A**  
**TK419 Exterior Physical Attributes**

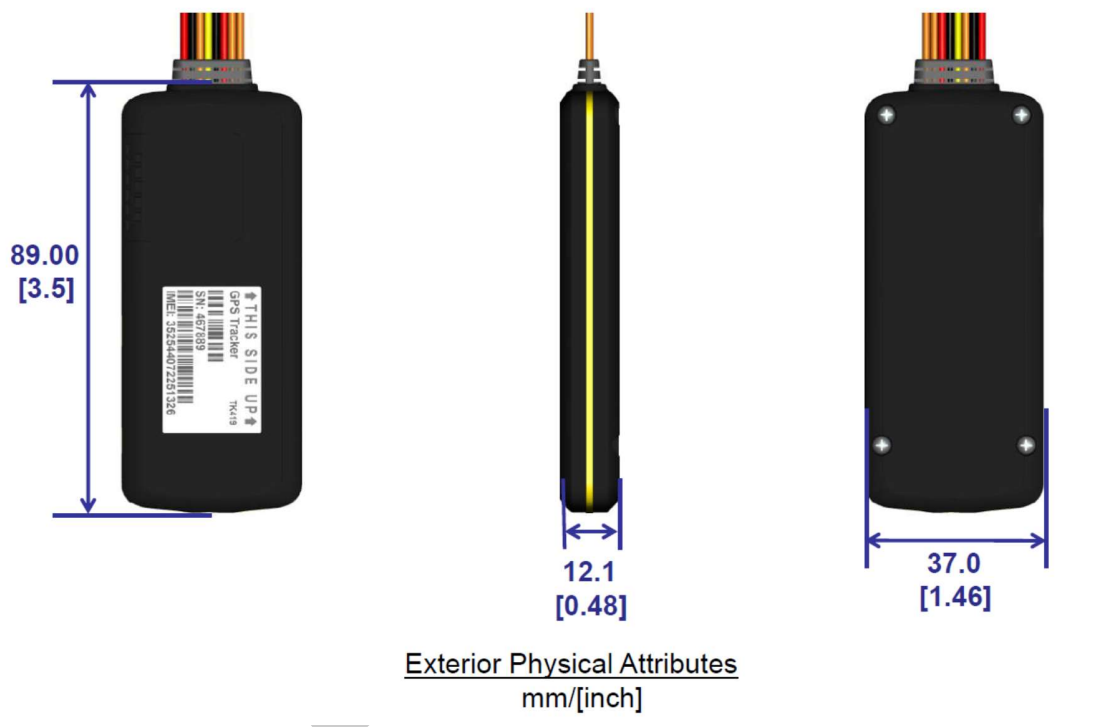

**Figure 3B**  
**TK419 Exterior Physical Attributes**

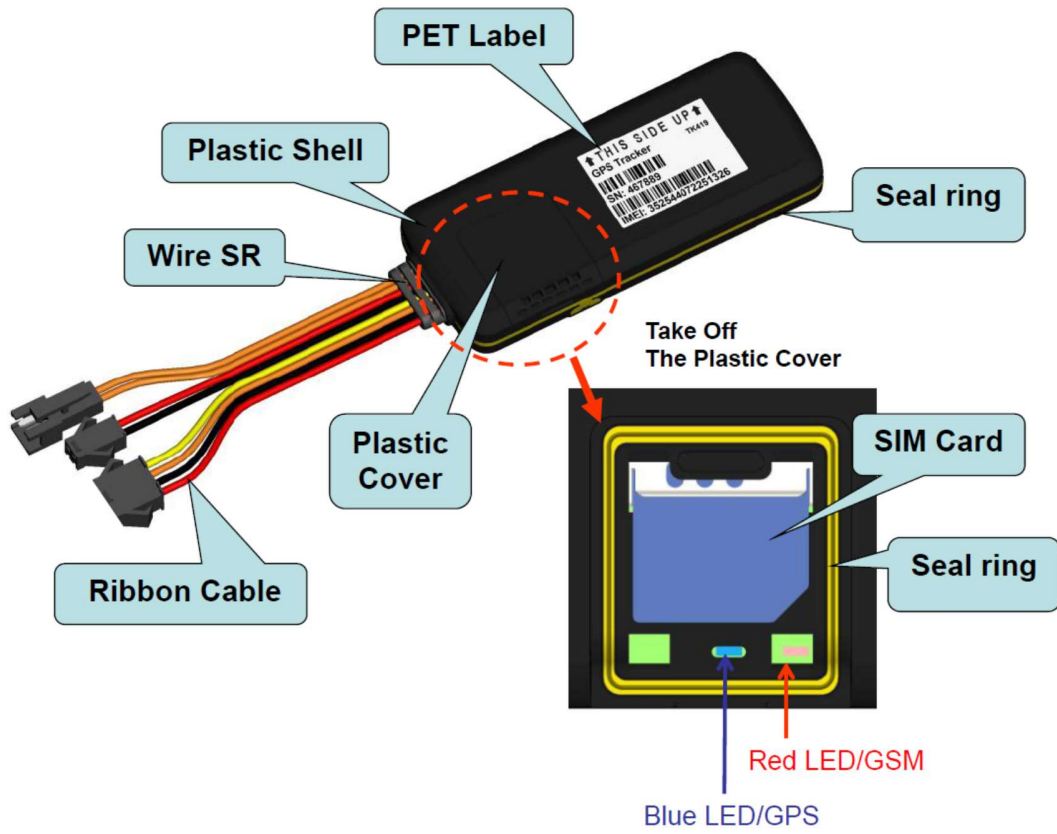

DRAFT

## Power interface

The power input interface on the pigtail harness are described in the table below.

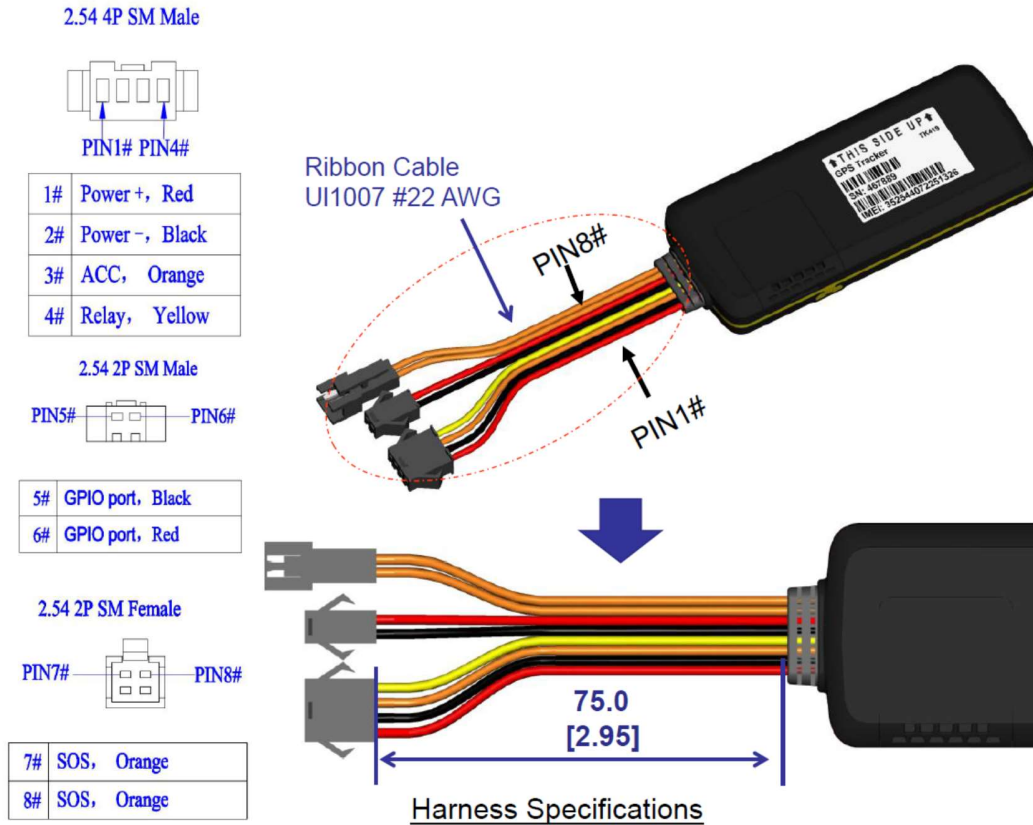

## Expanding function for pin7 & pin8 as followings:

(Optional functions, special software driving or modifying hardware before shipment)

- (1) Connecting external lithium battery (Maximum 4.2V).
- (2) Connecting external iButton interface for ID confirm.
- (3) Connecting external UART (TTL level) for data communication with server.

Port extension function

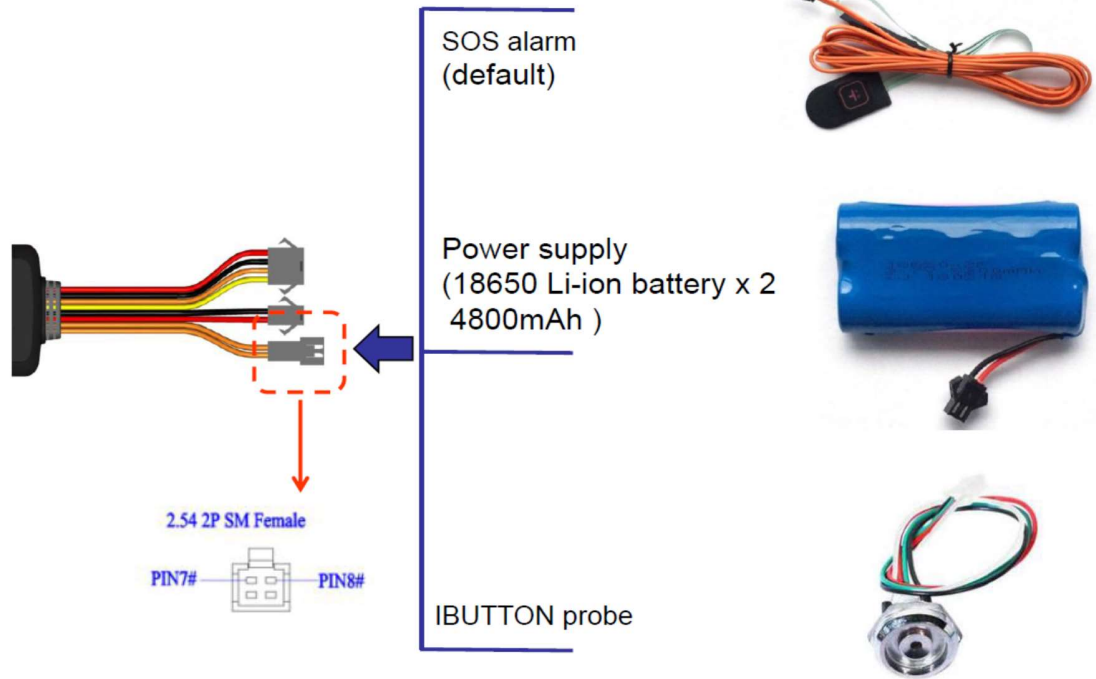

**LEDs**

The two status LEDs directly convey the status of the LTE and GPS subsystems as described in the table below. Indirectly, through their absence of a valid indication, they also provide power and operational status. These LEDs are color coded and located as shown in Figure 4.

Figure 4  
LED Orientation

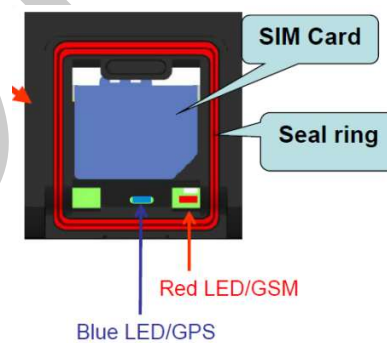

LED	Status
-----	--------

Blue	<b>On:</b> GPS satellites acquired <b>Flash:</b> 250ms/250ms duty cycle indicates GPS satellite search is in progress <b>Off:</b> GPS subsystem fault
Red	<b>On:</b> Indicates LTE or WCDMA or GPRS connection is made <b>Flash:</b> 250ms/250ms duty cycle indicates LTE or WCDMA or GSM subsystem initialization <b>Off:</b> GSM or WCDMA or LTE subsystem fault

DRAFT